

INSTALLATION & OPERATION  
INSTRUCTIONS MANUAL

V-SERIES FILTERS

V-3VERT

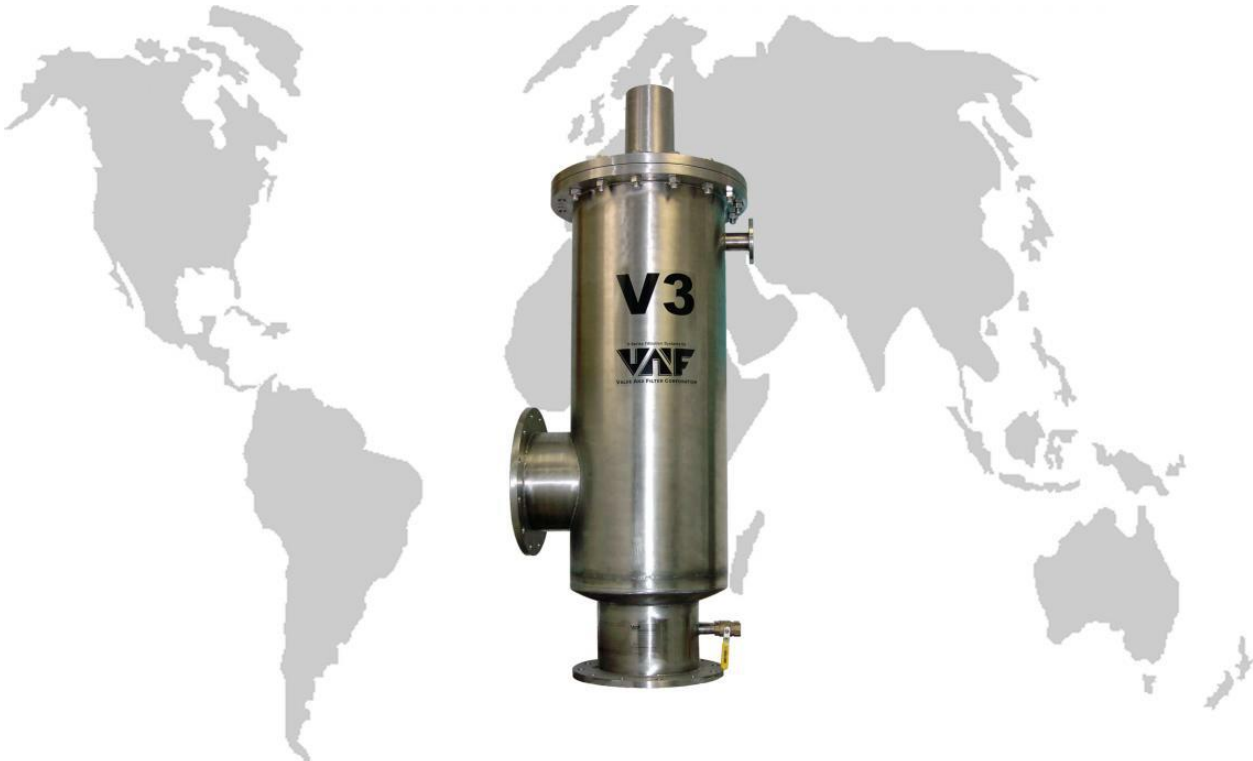



## Revision History

---

**NOTE:** Ensure printed copies of this manual are kept up to date with the latest revisions.

---

Revision	Date	Description
Revision 0	Dec-2016	Initial Issue
Revision 1	Nov-2018	
Revision 2	Dec-2020	
Revision 3	Feb-2022	
Revision 4	Mar-2022	
Revision 5	Jun-2023	
Revision 6	Mar-2024	

# CONTENTS

- PREFACE PAGES..... 1**
  - DISCLAIMER STATEMENT .....1
  - PROPRIETARY RIGHTS STATEMENT .....1
  - MANUAL USER’S GUIDE .....2
  - EQUIPMENT SUPPORT.....3
    - CONTACT US .....3
  - WARRANTY .....3
  
- FOREWORD..... 4**
  
- 1.0 SAFETY & REGULATION..... 5**
  - 1.1 REQUIREMENTS.....5
  - 1.2 STRUCTURAL SUPPORT AND RETENTION.....5
  - 1.3 OPERATING PRESSURE .....6
  - 1.4 DISCHARGE WASTEWATER.....7
  - 1.5 ELECTRICAL.....7
  
- 2.0 INTRODUCTION ..... 8**
  - 2.1 DESCRIPTION .....8
  - 2.2 THEORY OF OPERATION .....8
  - 2.3 RECOMMENDED APPLICATIONS..... 10
  - 2.4 DESIGN FEATURES ..... 10
  - 2.5 DESIGN SPECIFICATIONS..... 11
  - 2.6 CONTROLLER INFORMATION..... 12
  
- 3.0 APPLICATION..... 13**
  - 3.1 SYSTEM REQUIREMENTS..... 13
    - 3.1.1 LINE SIZE ..... 13
    - 3.1.2 CONFIGURATION ..... 13
    - 3.1.3 PRESSURE..... 14
    - 3.1.4 FLOW ..... 15

3.1.5	TEMPERATURE.....	15
3.1.6	DIRT LOAD .....	15
3.1.7	FILTER SCREEN.....	15
3.1.8	INDUSTRY.....	16
<b>4.0</b>	<b>INSTALLATION &amp; HOOK-UP.....</b>	<b>17</b>
4.1	MECHANICAL HOOK-UP AND ORIENTATION .....	17
4.2	PLUMBING HOOK-UP.....	17
<b>5.0</b>	<b>OPERATION &amp; ADJUSTMENTS.....</b>	<b>19</b>
5.1	START -UP .....	19
5.1.1	POWER CONTROLLER.....	19
5.1.2	PRESSURIZE FILTER.....	19
5.1.3	CHECK FOR LEAKS .....	19
5.1.4	START FILTRATION.....	19
<b>6.0</b>	<b>MAINTENANCE .....</b>	<b>20</b>
6.1	DISASSEMBLY OF V-3 VERT FILTER.....	20
6.2	ASSEMBLY OF V-SERIES FILTER.....	23
6.3	DISASSEMBLY OF INTERNAL ASSEMBLY AND PAWL REMOVAL .....	24
6.4	ASSEMBLY OF INTERNAL ASSEMBLY AND PAWL INSTALLATION .....	25
<b>7.0</b>	<b>WINTERIZING .....</b>	<b>26</b>
<b>8.0</b>	<b>TROUBLESHOOTING.....</b>	<b>28</b>
8.1	PROBLEM - Flushing diaphragm valve is not closing during start-up.....	28
8.2	PROBLEM - Differential pressure never decreases, only builds. ....	28
8.3	PROBLEM - Flush valve chatters .....	28
8.4	PROBLEM - Frequent or continuous flushing.....	29
8.5	PROBLEM - Water exiting the filter outlet is not sufficiently clean.....	31
8.6	TROUBLESHOOTING HINTS:.....	31
8.7	TROUBLESHOOTING DIAGNOSTICS: .....	32
<b>9.0</b>	<b>EXPLODED VIEW.....</b>	<b>32</b>

# PREFACE PAGES

## **DISCLAIMER STATEMENT**

The operation and maintenance manual should provide complete and accurate information to meet your operating and/or service requirements based on the information available at the time of publication. The information in this manual may not cover all operating details or variations or provide for all conditions in connection with installation, operation, and maintenance. Should questions arise which are not answered specifically in this manual, contact your water system supplier.

VAF Screen Filters reserves the right to make engineering refinements that may not be reflected in these manuals. The material in these manuals is for informational purposes and is subject to change without notice.

## **PROPRIETARY RIGHTS STATEMENT**

This manual discloses information in which VAF Screen Filters has proprietary rights. Neither receipt nor possession of this manual confers or transfers any right to the client, and by its retention hereof, the client acknowledges that it will not reproduce or cause to be reproduced, in whole or in part, any such information except by written permission from VAF Screen Filters. The client shall have the right to use and disclose to its employees the information contained herein for the purpose of operating and maintaining the VAF Screen Filters equipment, and for no other purpose.

In the event the content of this manual is altered, or section/items are omitted during a reproduction, in whole or in part, and instructions or definitions within the reproduction result in personal injury to those who follow the altered instructions, the burden of responsibility for personal injury falls solely on the party who affects the reproduction.

**©Copyright 2026 VAF Screen Filters**

Printed in the United States of America. All rights reserved.

*This book or parts thereof may not be reproduced in any form without the written permission of the publishers.*



## MANUAL USER'S GUIDE

This manual describes the procedures necessary to install, operate, and maintain your VAF Filtration Systems. Please read this manual carefully before installing and operating your equipment. The equipment warranty may be voided if installation or operation instructions are not followed correctly.

Warnings, cautions, and notes are used to attract attention to essential or critical information in a manual. Warnings and Cautions will appear before the text associated with them, and notes can appear either before or after associated text.

---

**WARNING**      Warnings indicate a condition, practice, or procedure which must be observed to avoid personal injury or fatalities.

---

---

**CAUTION**      Cautions indicate a situation that may cause damage or destruction of equipment or may pose a long-term health hazard

---

---

**NOTE:**      Notes are used to add information, state exceptions, and point out areas that may be of greater interest or importance.

---



## EQUIPMENT SUPPORT

VAF Screen Filters continually strives to provide safe, trouble-free equipment using the optimum technology for your application. If problems should develop, VAF Screen Filters worldwide network of technical support will be available to provide assistance. For service, sales, parts, or additional manual copies please visit website: <https://vafscreenfilters.com>.

## CONTACT US

### ADDRESS

VAF Screen Filters  
5640 Logistics Dr #100  
Alpharetta, GA 30004

### E-mail

[solutions@fisbrands.com](mailto:solutions@fisbrands.com)

### Website

<https://vafscreenfilters.com>

### *Spare Parts and Field Service*

470-222-2890

## WARRANTY

For additional information regarding VAF Screen Filters Warranty, please reference the Standard Terms of Sale document provided.



## FOREWORD

Thank you for purchasing VAF Filtration Systems' V-Series automatic backwash filter. The V-Series filter and electronic backwash controller function integrally, providing more effective, lower cost water filtration than traditional filtration systems.

Follow procedures contained in this Owner's Manual for proper installation, start-up, operation, and maintenance of the filter and backwash controller. Failure to follow these procedures may void warranty on the product. Refer to the Product Warranty for more details.

VAF designed and built your filter employing the latest technologies and engineering materials. As a consequence, you own the best automatic self-cleaning screen water filter available. And your filter is MADE in the U.S.A.

Quality at VAF Filtration Systems goes far beyond our line of products. Feel free to call our professional staff directly at headquarters in Denver, Colorado.

## IMPORTANT - READ THIS FIRST

### HANDLING AND INSTALLATION:

This filter is constructed of stainless steel. It is NOT designed to accept pipe stress or undue mechanical stress of any kind including stress imposed by an improperly designed mounting structure. Use caution and common sense when uncrating, moving and installing the filter. Do not use excessive force in tightening mounting straps or bolts. Never force the filter body to accommodate a mounting structure. Piping should be self-supporting and correctly aligned in all planes. Imposing undue stress may warp or make the filter body out-of-round and will void the warranty.

## 1.0 SAFETY & REGULATION

### 1.1 REQUIREMENTS

---

**WARNING** Wear, as required, hard hat, safety goggles, rubber gloves, steel-toed boots, respirator mask and protective clothing when servicing the filter unit. Abide by applicable OSHA and industrial standards for your particular application.

---

V-Series filters and electronic backwash controllers are designed for safe operation when used according to instructions, specifications, procedures, and requirements contained in this manual. It is the responsibility of the filter owner to verify that the filter is operating accordingly. Assure that all applicable rules, regulations, requirements, standards, and codes, either local, national or industrial are followed in installation, operation, maintenance, servicing and moving of the filter and backwash controller. Consult our technical staff with your questions on safe operation of the filter.

### 1.2 STRUCTURAL SUPPORT AND RETENTION

---

**WARNING** Depending on size of standard filter models, a flooded (filled with water) V-Series filter weighs between 35-840 kg (80 and 1850 pounds). Exercise caution when transporting, installing or taking filter out of service as the weight of the filter may cause serious injury or death from falling on persons

---

---

**CAUTION** When erecting the filter during installation (or taking filter out of service), make sure the filter is properly supported by the retention system. Remove retention systems only after filter has been properly secured to piping and adequately supported. If the existing piping arrangement is used as structural support for the filter, check to assure that it is structurally adequate considering the flooded weight of the filter.

---



Figure 1: Inlet/outlet piping support



Figure 2: Saddle type filter support

Due to the methods used to construct the V-Series filter, it is recommended that the filter be supported primarily by the inlet and outlet piping (Figure 1).

If this configuration is not possible, a saddle type support is recommended (Figure 2). Never support the filter body with a small contact area between the filter and support. It is also important that piping out of the flush valve is in a semi-rigid configuration to prevent twisting of the body due to torque created by the flush water exiting the piping. Failure to follow these guidelines may cause the filter body to warp or dent and will void the warranty.

## 1.3 OPERATING PRESSURE

### CAUTION

Periodically check welds and hydraulic connections as part of general maintenance. Follow applicable power piping code. For standard filter models, keep the operating pressure below the 10 bar (150 psi) maximum safe pressure limit. In applications requiring a higher-pressure limit, consult the manufacturer regarding a design that will safely satisfy higher pressure requirements. Assure bolts and nuts of covers and flanged connections are uniformly tightened before pressurizing the filter. Before servicing filter internals, slowly open the filter bypass valve, then slowly close the filter isolation valves. Manually backflush the filter to depressurize, then drain the filter. Before servicing the filter, make sure the filter is depressurized in both the inlet chamber and drive chamber compartments (see Figure 4). Measure the internal pressure

separately in both chambers using the pressure gauge mounted to the filter outlet. **DO NOT REMOVE COVER OR ANY PRESSURE FITTING UNTIL YOU ARE SURE PRESSURE IN THE FILTER IS ZERO.**

---

## 1.4 DISCHARGE WASTEWATER

Conform to all applicable standards, codes and regulations for your particular industry and application.

Follow USEPA regulations when discharging backflush water.

## 1.5 ELECTRICAL

---

### **WARNING**

When wiring the electronic backwash controller, follow the instructions in the manual along with local code and National Electrical Code. An explosion-proof solenoid (available as an alternate part) is required when the filter is used in a potentially flammable atmospheric environment. A filter installed with a general-purpose solenoid can ignite combustible fluids. Avoid touching a solenoid that has been electrically energized as heat from operation may cause burning of skin. Turn off electrical power to the controller and solenoid before servicing either the controller or the filter.

---

## 2.0 INTRODUCTION

### 2.1 DESCRIPTION

The V-Series is an automatic, self-cleaning, screen water filter. The filtration system consists of a tank body, a fine screen, AWWA class D inlet/outlet flanges, a flush valve and a filter controller.

### 2.2 THEORY OF OPERATION

Please refer to Figure 3.

Dirty water enters the filter through the inlet (1) and then passes through the coarse screen (2) from the outside in. It flows from the inside of the coarse screen to the inside of the fine screen and then passes through the fine screen (3) from the inside out. Dirt is collected on the inside surface of the fine screen. The clean filtered water then exits through the filter outlet (4) and on to the system.

As the dirt or cake builds up on the inside surface of the fine screen, the pressure drops across the screen increases. When the pressure drops, (the DP or Differential pressure) reaches a preset level (0.5 bar or 7 psi), the filter controller starts a flush cycle by opening a flush valve on the flush line (5). This flush valve exhausts the drive chamber to atmosphere at “0” bar/psi.

The flush line (5) is connected to the drive chamber which is separated from the filtration chamber by a drive chamber partition (6). However, the dirt collector (7) (a hollow pipe with dirt collector nozzles) extends through the partition (6), thus providing a “path” from the dirt collector nozzles (8) through the hydraulic drive (9), into the drive chamber and out the flush line (5) to atmosphere. The pressure around the dirt collector nozzle (8) is the pressure inside the filter and as water flows through the “path”, it drops to “0” bar/psi when it leaves the flush line (5). This creates an aggressive “suction” at the dirt collector nozzle (8) opening. The dirt collector nozzle (8) clearance at the fine screen (3) is very small. So, the extreme low pressure at the nozzle opening creates a backflow which “sucks” the dirt from the fine screen (3).

The hydraulic drive (9) has jets on opposite sides near its ends. Water jetting out of these openings (coming from the dirt collector nozzles (8)) creates a reaction force (like a pin

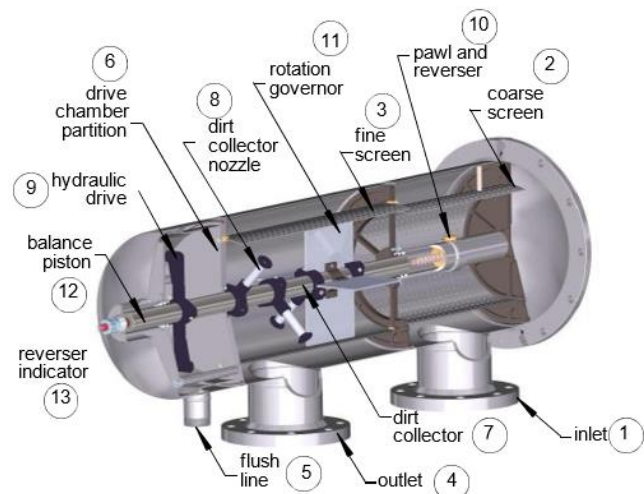

Figure 3: V-Series internal cutaway

wheel) which rotates the drive (9) and the dirt collector (7). As the dirt collector (7) rotates, each dirt collector nozzle (8) cleans a band on the fine screen (3).

As the dirt collector (7) rotates, the reverser (10) (works like the level winder on your fishing reel) causes the hydraulic drive (9) / dirt collector (7) / dirt collector nozzle (8) assembly to move back and forth.

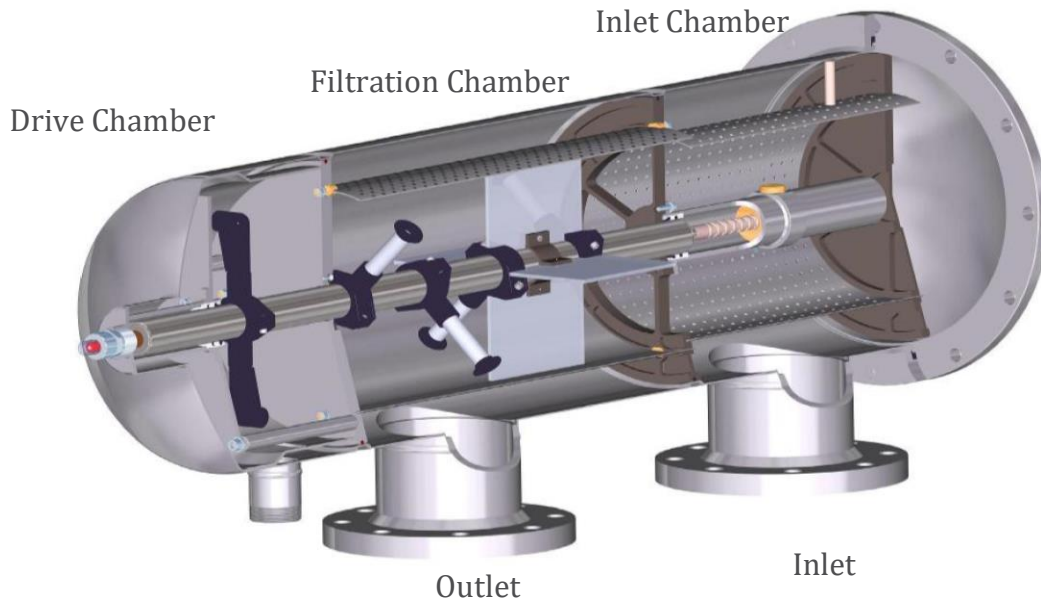

Figure 4: V-Series Chamber

The rotation governor (11) helps control the rotation speed of the dirt collector (7) assembly. The balance piston (12) helps balance the transverse pressure on the assembly, and powers the reverser indicator (13) which provides visual indication of the dirt collector (7) assembly movement showing that the entire cleaning system is operating properly during the rinse cycle.

---

**NOTE:** After a preset time, the flush valve closes, and the rinse cycle is complete. Very little rinse water is used for each rinse. Please note the filter continues to supply water to the system during the rinse cycle.

---

## 2.3 RECOMMENDED APPLICATIONS

Ideal for filtering out suspended solids larger than 10 micron such as silt, scale, sand, rust, dirt, and organic material, like algae, from virtually all types of water sources.

## 2.4 DESIGN FEATURES

**NOTE:** Among the many features of the V-Series is its avoidance of the danger of forcing contaminated water back into the system, which can happen with a sand media filter. The V-Series filter will deliver clean water or no water.

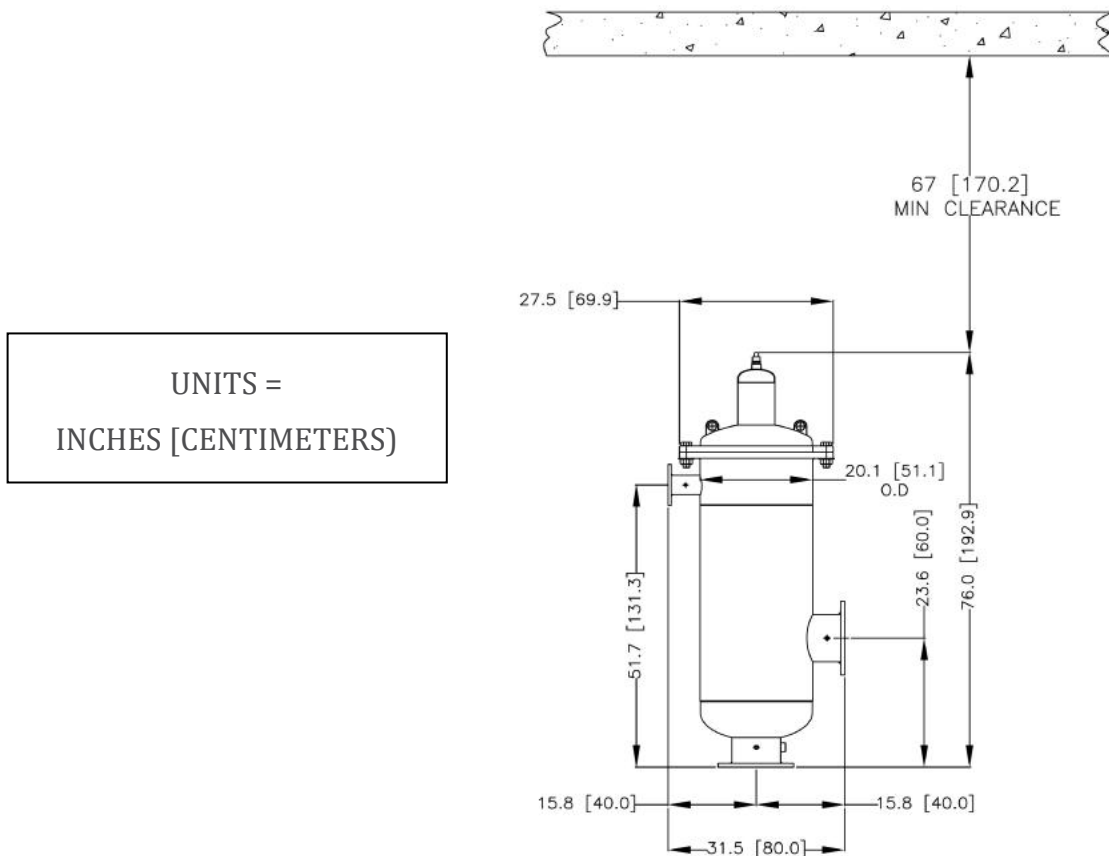

Figure 5: V-Series Filter



Model	Flush Line	Inlet/Outlet	Top Clearance		Screen Area		Nominal Flow			Flush Flow		No. of Nozzles
			mm	in	Cm <sup>2</sup>	in <sup>2</sup>	m <sup>3</sup> /hr (gpm)			Liters	Gallons	
							100 mic	200 mic	300 mic			
V-3 VERT	3"	8-10-12-14	1702.0	67.0	10942	1,696	464 m <sup>3</sup> /hr, (2040 gpm)	618 m <sup>3</sup> /hr, (2720 gpm)	695 m <sup>3</sup> /hr, (3060 gpm)	125	33	6

Note: VAF "nominal flow" rates are for 100, 200 and 300 micron filtration ratings for demonstration purposes only. Larger micron ratings result in higher allowable flow rates. Smaller micron ratings result in lower allowable flow rates. Call VAF for details.

The most predominant feature is its ability to remove organics such as algae as well as other suspended particles such as sand and scale.

The entire back-flushing mechanism and fine screen assembly is modular and is removed from the filter body as a complete unit without disruption of the plumbing. This makes it very easy to inspect and repair if necessary.

## 2.5 DESIGN SPECIFICATIONS

Please refer to Figure 3.

<b>Materials</b>	Tank	Type 316L stainless steel Also available in 2205 stainless steel
	Reaction Motor and Nozzle assembly	Glass filled Nylon and CPVC
	Filter screen	Type 316L stainless steel Also available in 904L stainless steel
<b>Pressure Lost Through Filter</b>	Adjustable flush set point up to 1 bar (15 psi), at which backwash is initiated. Less than 0.07 bar (1 psi) loss with a clean screen element. Normal flush setting is 0.5 bar (7 or 8 psi).	
<b>Controls</b>	Electric, programmable, 120VAC.	
<b>Pressure Range</b>	2 to 10.3 bar (30 to 150 psi) maximum. Custom filters available up to 300 psi Note: A minimum of 30 psi on outlet back pressure is required to assure efficient cleaning and proper actuation of backwash mode.	
<b>Temperature Range</b>	0° to 80° C maximum (32° to 176° F)	



## 2.6 CONTROLLER INFORMATION

**MicroFlush™ Controller:** The VAF MicroFlush (MF) Controller provides multiple advanced features that allow for the monitoring and control of a single filter or filtration system, not the least of which is the “failsafe” program to prevent cooling tower basin drainage. The MF can monitor a single filter or up to 4 filters in a system, when installed in parallel. The MF controller monitors the filter(s) Differential Pressure (DP) and automatically initiates a flushing cycle when the DP reaches the preset 0.5 bar or 7 psi across the filter’s inlet/outlet.

The MF controller provides the ability for data logging so that accurate monitoring and historical data can be accessed by means of the MF display. The controller is housed in a NEMA 3R weather resistant enclosure that is suitable for indoor or outdoor installation. The MF controller is offered with either Battery, Solar, 120VAC or 220VAC power inputs to maximize installation flexibility at any location. The controller provides outputs to operate solenoid diaphragm flush valves, electronically actuated ball flush valves or latching solenoids and provides terminal connections for “optional device” outputs, such as throttling valves or booster pumps. The MF4 (four filter model) also includes NO and NC closed contacts that can be used by the MF to receive and send notice of an alarm conditions, which are programmable by the operator. While very economically priced, the MicroFlush provides the most features of any filter controller offered today! Not only monitoring and controlling the V-Series filters, but other filter types as well.

## 3.0 APPLICATION

### 3.1 SYSTEM REQUIREMENTS

Refer to Page 10-11 for V-Series filter specifications. When designing and/or considering the system in which the V-Series will be installed, evaluate:

1. Line Size
2. Configuration
3. Pressure
4. Flow
5. Temperature
6. Dirt Load
7. Filter Screen
8. Industry

#### 3.1.1 LINE SIZE

The filter shall be sized for the application, such that velocity, pressure and flow rate are nominally maintained as water flows through the filter. A filter sized hydraulically too small for the application results in a relatively high flow rate through the filter and excessive pressure drop across the filter. Also, dirt builds up very quickly on the filter screen, causing frequent backwash cycling.

#### 3.1.2 CONFIGURATION

---

**NOTE:** It is highly recommended to install the filter with a piping arrangement allowing full by-pass flow, especially for flow-critical applications. In this way, service and maintenance can be performed on the filter without shutting down process flow. The standard on-line (pedestal) configuration is very convenient for establishing a by-pass piping arrangement.

---

Multiple filters may be used hydraulically in-parallel or hydraulically in-series. In applications where the dirt load is relatively high and the particle size is relatively uniform, a bank of in-parallel filters, all having the same screen mesh size, is recommended. In applications where the dirt load is relatively high and the particle size is non-uniform, installing filters in-series with decreasing mesh size in the direction of flow may be

effective. Whether filters are configured in-parallel or in-series, they are backwashed one at a time to prevent excessive pressure drop within the piping system.

In applications where the dirt load is nominal, a single filter (equipped with a proper screen mesh size) is typically sufficient.

### 3.1.3 PRESSURE

Properly size a hydraulic pump to keep the operating pressure within the design limits of the filter. Keep the pressure inside the filter below the 10 bar (150 psi) maximum safe allowable pressure limit. The pump must maintain a **MINIMUM** pressure of 2 bar (30 psi) at the filter inlet **DURING A BACKFLUSH CYCLE** for the filter to backwash properly. If the filter is to be installed within an existing piping system, determine whether or not the existing pump will be sufficient to maintain the 2 bar (30 psi) minimum pressure requirement.

---

**NOTE:** For filter installations within low pressure systems (less than 2 bar or 30 psi), modifications can be made to boost pressure during the backwash mode, allowing proper flushing operation. Modifications to boost pressure include booster pumps, sustaining valves and external water sources. Consult VAF with inquiries on pressure requirements.

---

---

**CAUTION** During normal filtering mode (when the filter is not backflushing), keep the differential pressure across the filter below 0.7 bar or 10 psi to prevent:

---

1. pushing dirt through the fine filter screen
2. embedding dirt in the filter screen mesh.



Figure 6: 3-Position manual valve and pressure gauge

The V-Series filter is equipped with a 3-position manual valve and pressure gauge (Figure 6). This allows the pressure to be read on the same gauge at both the filter inlet and outlet as well as in the filter motor compartment.

### 3.1.4 FLOW

---

**CAUTION** Keep the flow rate through the filter below the nominal flow rate specified on Page 10 to insure optimum performance of the filter. Contact VAF engineers for flows higher than the nominal rates.

---

### 3.1.5 TEMPERATURE

---

**CAUTION** Keep the temperature of the water below 80°C (176°F) to prevent damage to the filter internals. Keep water within the filter above 0°C (32°F) to prevent freezing.

---

### 3.1.6 DIRT LOAD

The V-Series will filter out many types of particulates in water. In special applications, it may be necessary to modify the standard filter to achieve proper filtration. Filters placed into existing loop systems having relatively high dirt concentration (load), typically backflush often at first. In time, as dirt is removed from the water, the frequency of backflushing will decrease. In these applications where existing systems are extremely dirty, it is recommended to initially equip the filter with a screen having relatively large micron openings. After the frequency of backflushes decreases and then stabilizes, replace with a screen having smaller micron openings continue this process until a satisfactory level of filtration is achieved.

---

**NOTE:** For existing cooling tower installations it is recommended the basin is thoroughly cleaned prior to putting the filtration equipment on line.

---

### 3.1.7 FILTER SCREEN

VAF utilizes a sintered, three-layer, nominal rated screen for maximum open area and accurate filtration degrees. First layer is a coarse, 3/16" (4.7mm) perforation, thicker backing for rigidity. Second layer is a 500um weave wire screen to allow for a greater amount of flow paths through the fine screen. Third layer is the fine screen where particulate will be captured on the inside of the screen.



It has the following advantages.

- Sintering allows for the maximum amount of open area as there is no adhesive or welding material to block flow.
- Rated for the maximum amount of particulate removal at the desired filtration degree.
- All 316LSS construction for maximum product lifespan and durability.
- Greatest debris holding capacity for less frequent flushing

### 3.1.8 INDUSTRY

Water has been a choice process and cooling fluid that until recently has been readily available, relatively inexpensive, and easily discharged when dirty. With the onset of diminished supply, rising cost and increasingly stringent environmental regulation, V-Series water filters have found increasing application across many industries. Some applications of the V-Series include steel mills, food processing, manufacturing, agricultural irrigation, mining, and cooling towers. The V-Series can be used in virtually any application where water is used. Because of widespread use, detailed explanation of how these filters shall be applied in each and every industry is beyond the scope of this manual. Nevertheless, commonalties amongst different filter applications warrants general discussion of installation, start-up, troubleshooting, maintenance, parts & service, and operation. Refer to the following Sections of this manual for information on these topics.

## 4.0 INSTALLATION & HOOK-UP

### 4.1 MECHANICAL HOOK-UP AND ORIENTATION

The positioning of the filter tank should be determined in order to allow easy access and removal of the filter element. A minimum amount of clearance at the lid end is required. See the specifications on page 10 for clearance required for your model. It is recommended that the filter be mounted in a horizontal orientation to reduce wear on the moving parts. Always install filter on discharge side of pump, 2 bar (30 psi) minimum required.

The location of the flushing valve should provide no obstruction to its operation.

The tank can be supported by the inlet/outlet flanges or can be mounted on a stand if desired. See the Structural Support and Retention in Section 1 (Safety and Regulation) for figures and suggestions.

### 4.2 PLUMBING HOOK-UP

Backwash discharge pipe can be the same diameter but should be larger than the flush valve diameter with no more than one elbow and a downward slope to the sump or drain. Any restrictions in the backwash line will reduce the cleaning efficiency of the filter. For applications with greater than 5.2 bar (75 psi), it is recommended that the flush valve be throttled using the limit stop until 3.4- 4.1 bar (50-60 psi) is seen between the inlet and flush chambers during a flush cycle.

Tubing connecting the inlet and outlet of the filter to the differential pressure switch/gage or pressure transducers on the selected controller should be installed. The inlet is connected to the high-pressure port, and the outlet is connected to the low-pressure port (Figure 7). Carefully check to ensure these connections are not reversed. Consult your controller manual for more information.



Figure 7: High- & low-pressure ports on the DP switch/gauge

---

**NOTE:** If flooding is a concern, VAF Screen Filters recommends having a containment plan in place in case of a system failure.

---



Figure 8: Flush valve

If using a diaphragm type flush valve with solenoid actuator (Figure 8), the supply to the solenoid must be connected to a pressure source, typically either a port on the inlet of the valve or to the inlet of the filter. The solenoid must also be connected to the controller. Consult your controller manual for specific wiring information.

If using an electrically actuated ball valve (Figure 9) install per wiring diagram shown in Figure 9A to the controller circuit board. This terminal outputs 24 VAC at a maximum of 1 amp. An inter-  
pose 24VAC relay will be required if the value requires a different voltage or amperage. Other flush valve options are available, consult factory for details.



Figure 9: Electrically actuated ball valve

When designing piping to and from the filter, consider installing bypass piping and valves along with isolation valves. This allows the filter to be taken offline without interrupting the flow.

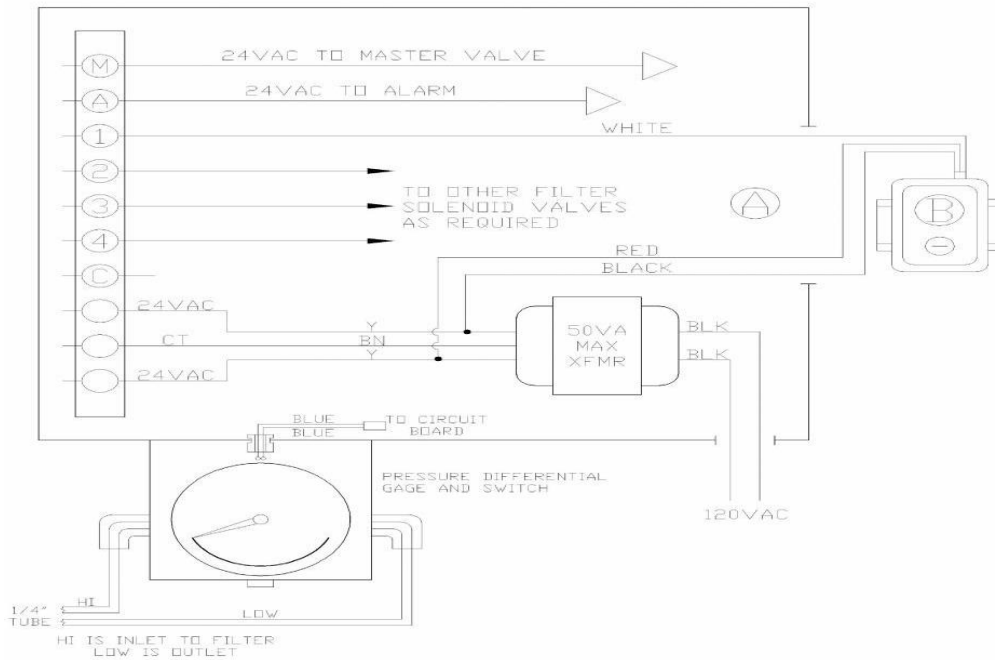

Figure 9A

## 5.0 OPERATION & ADJUSTMENTS

### 5.1 START -UP

#### 5.1.1 POWER CONTROLLER

Ensure that there is power to the controller and that it is on. See Section 8 for controller settings and programming.

#### 5.1.2 PRESSURIZE FILTER

During the initial start-up of the filter, with the outlet valve closed, slowly open the inlet valve in order to flood the filter and to pressurize the filter body. Allow air to bleed from the filter if equipped with an air release valve.

#### 5.1.3 CHECK FOR LEAKS

---

**WARNING**      **Once the filter is flooded and pressurized, check for any leaks. If leaks are detected, isolate filter, reduce pressure immediately, and perform necessary steps to eliminate leaks.**

---

#### 5.1.4 START FILTRATION

Slowly open the outlet valve to allow the filter to begin operation. Initially, it is advisable to open the outlet valve only partially to slowly fill the downstream lines and avoid line surges. The filter will slowly develop a dirt cake on the screen. As it does, the differential pressure across the screen will rise. Once the differential pressure reaches its current setting (factory set at 0.5 bar or 7 psi) the controller will automatically initiate a backwash by opening the flush valve. After the backwash is complete, the differential pressure should have returned to zero. Once the filter has gone through several successful backwash cycles the outlet valve can be opened and the flow rate through the filter can be increased. If problems are encountered during start-up, consult the troubleshooting section of this manual or call VAF's field service team.

## 6.0 MAINTENANCE

### 6.1 DISASSEMBLY OF V-3 VERT FILTER

Required tools:

- 3/4", 15/16" and 7/16" wrenches or sockets and ratchet
- Large flathead screwdriver
- Needle nose pliers
- Set of Allen wrenches

1. Isolate the filter by first turning the outlet valve off, then turn the inlet valve off.
2. Relieve pressure inside of filter body by initiating a manual flush, opening a drain valve or slightly opening filter lid.
3. Remove 5/8" nuts, bolts and washers securing the lid (Figure 10) and remove lid.
4. Store lid convex side down to prevent seal damage (Figure 11).
5. Remove coarse screen cap (Figure 12) and coarse screen (Figure 13).
6. Make note of the circular channel in which the coarse screen must sit, located in both the upper bulkhead and the cap.



Figure 10: Removal of lid



Figure 11: Correct lid storage



Figure 12: Removal of coarse screen cap



Figure 13: Removal of coarse screen

7. Place some cardboard over the filter inlet, to prevent parts or tools from falling into the inlet line (Figure 14).
8. Using the 3/4" wrench or socket, loosen the three locking nuts (Figure 15).
9. With the large flathead screwdriver, turn the three bulkhead locking bolts 1/4 turn counterclockwise to free the internal assembly (Figure 16).

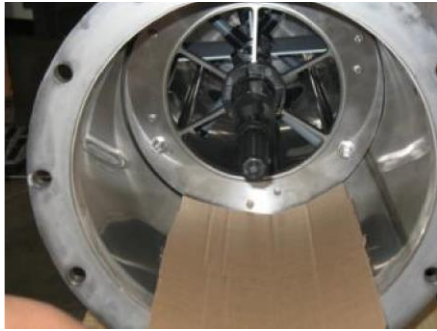

Figure 14: Covering the inlet line



Figure 15: Locking nut



Figure 16: Unlocking the internal assembly

10. Use the reverser as a handle to partially remove the internal assembly (Figure 17).

---

**NOTE:** The next step will require an overhead crane or other heavy equipment to support the weight of the assembly as it is removed from the body. The V3 internal assembly weighs over 68 kg (150 lbs).

---

11. Use one of the legs on the lower bulkhead to support the internal assembly before the lower bulkhead exits the body to prevent scarring the body or denting the screen (Figure 18).

---

**NOTE:** Filter assembly must be horizontal for the next two steps. Failure in doing so may result in damage to assembly components.

---

12. Remove the pawl retainer (Figure 19). When assembling, check that retainer O-ring is in place.



Figure 17: Internal assembly removal



Figure 18: Supporting the internal assembly



Figure 19: Removing pawl retainer



Figure 20: Removal of pawl



Figure 21: Removal of Allen screws



Figure 22: Upper bulkhead removal

13. Remove pawl with needle nose pliers (Figure 20).
14. Using 3/16" Allen wrench, remove 4 Allen screws from upper bulkhead (Figure 21), and lift upper bulkhead off of support rods (Figure 22).
15. To remove reverser housing, unscrew four 3/16" Allen head screws from base of upper bulkhead (Figure 23).
16. Lift screen off of assembly (Figure 24).

---

**NOTE:** Before performing the next step, note the orientation of the hydraulic motor. Incorrect assembly will result in malfunction and potentially damaged internal parts.

---

17. Unscrew two 9/64" hydraulic motor Allen screws and remove the hydraulic motor (Figure 25).



Figure 23: Reverser housing mounting screws



Figure 24: Screen removal



Figure 25: Removal of motor

18. Slide rotor assembly out of the lower bulkhead (Figure 26).

19. To remove flush indicator, unscrew indicator housing (Figure 27).



Figure 27: Flush indicator



Figure 26: Rotor removal

## 6.2 ASSEMBLY OF V-SERIES FILTER

Follow disassembly instructions in reverse order.

### **MUST READ BEFORE ASSEMBLING.:**

When assembling the V-Series filter, the following **MUST** be considered

1. The floating gasket in the lower bulkhead must be placed face up (towards the reverser) in order to function properly.
2. Do not lubricate the pawl and reverser at any time. Lubricating may damage the reverser material.
3. Filter elements must fit into the grooves in the differing bulkheads before securing the filter assembly to the filter frame. If this step is done incorrectly, the bulkheads may misalign causing the rotor assembly to rub or not rotate.
4. When mounting the rotor assembly into the filter assembly, the screen filters may be slipped out of the bulkhead grooves to ease installation. Ensure that the filters are placed properly into the grooves when complete.
5. Before installing the complete filter assembly into the tank, one must lubricate the bulkhead seals. Silicon based lubricant will work well unless prefiltering for a reverse osmosis system. In this case, use a glycerin-based lubricant. Failure to do so could result in seal failure and extreme difficulty in removing the filter assembly later.
6. Install lid seal in same orientation as when removed.
7. Tighten all nuts and bolts in a star pattern until snug. Do not over torque.
8. Never attempt to seat the internal assembly by tightening the cover nuts and forcing the unit in with the cover.

## 6.3 DISASSEMBLY OF INTERNAL ASSEMBLY AND PAWL REMOVAL

Required tools:

- 15/16", 7/16", and 5/16" wrenches or sockets and ratchet
  - Phillips and small flathead screwdriver
  - Needle nose and regular pliers
  - Set of Allen wrenches
1. Remove internals from tank as described in the "Disassembly of V-3 VERT Filters" section of the manual.
  2. The rotational governor paddles are removed by unscrewing the Phillips screws and 5/16" nut and bolt (Figure 28).
  3. The rotational governor can be removed by unscrewing the 3/16" Allen screw placed in-between two paddles (Figure 29) and sliding it off of the shaft.
  4. To remove the dirt collector's nozzles, remove two 9/64" Allen screws located at the bases of the nozzles (Figure 30).



Figure 28: Removing the rotor paddles

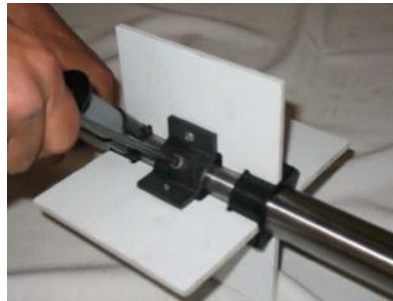

Figure 29: 3/16" Allen head screw



Figure 30: Nozzle removal



## 6.4 ASSEMBLY OF INTERNAL ASSEMBLY AND PAWL INSTALLATION

Follow disassembly of internal assembly in reverse order.

### **MUST READ BEFORE ASSEMBLING.:**

When assembling the internal assembly, the following **MUST** be considered:

1. When installing the pawl, hold it in place by applying pressure with your thumb, with the teeth aligned correctly. Rotate the shaft until the pawl is seated properly in the reverser threads. Ensure that O-ring is present in pawl retainer. Install the pawl retainer. Once the pawl is installed, rotate the shaft several times to ensure that it is functioning properly.
2. Hydraulic drive motor must be installed to generate COUNTER-CLOCKWISE rotation of the scanner shaft when in operation. Rotation is determined when looking at the internal assembly from the filter cover opening while assembly is installed in filter body.
3. Tighten all nuts and bolts in a star pattern until snug. Do not over torque.

---

**NOTE:** VAF Screen Filters recommends servicing every 6-12 months regardless of wear or as needed. Contact VAF Screen Filters for service kit options.

---

---

**NOTE:** Do not use power tools or impact to tighten hardware.

---

## 7.0 WINTERIZING

Required tools:

- 1/2", 9/16", 3/4" wrenches or sockets and ratchet
  - Teflon tape
  - Air nozzle and compressor
1. Follow steps 1-4 in Section 6 to relieve system pressure and remove filter lid.
  2. It is recommended at this time to remove, and pressure wash the internal assembly, and inspect for wear or damage. Detailed disassembly instructions can be found in Section 6.
  3. Remove pressure gauge using the 9/16" wrench (Figure 31).
  4. Using the air nozzle, blow out the water in all lines by rotating the 3-way ball valve to all 3 positions while applying air pressure to the valve body (Figure 32).
  5. Blow any remaining water out of gauge, reapply Teflon tape to threads, and reinstall gauge.
  6. The focus now moves to the flush valve and solenoid (Figure 33).



Figure 31: Removal of pressure gauge



Figure 32: Blowing out air lines



Figure 33: Flush valve



Figure 34: Removal of solenoid water supply lines

---

**NOTE:** It is not necessary to remove the flush valve from the filter body when winterizing

---

7. Remove the 2 quick connect solenoid water supply lines (Figure 34).
8. Loosen and remove the 3/4" nut and spring (USE CAUTION, DO NOT LOSE!!) from the solenoid body (Figures 35 and 36).
9. Remove plunger from solenoid body (Figure 37).



Figure 35: Loosening 3/4" Nut



Figure 36: Removal of nut & spring

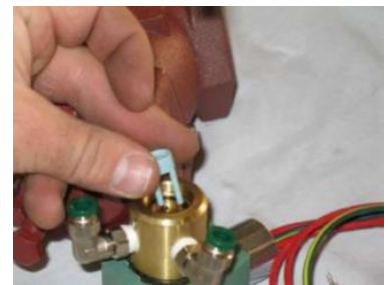

Figure 37: Plunger removal

10. Using the air nozzle, blow out remaining water in solenoid and solenoid water supply lines (Figures 38 and 39).
11. Remove 4 nuts and bolts (1/2") shown in (Figure 40) and remove the diaphragm cover plate (Figure 41).



Figure 38: Blowing out the solenoid supply lines



Figure 39: Blowing out the solenoid

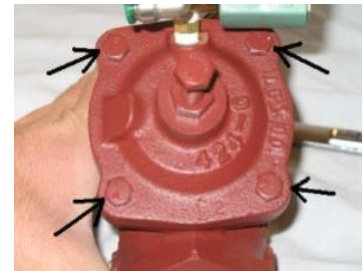

Figure 40: Diaphragm bolts



Figure 41: Removal of diaphragm cover plate



Figure 42: Removing water from cover plate

12. Blow excess water out of cover plate (Figure 42).
13. Reassemble flush valve and solenoid by following directions in reverse.

## 8.0 TROUBLESHOOTING

### 8.1 PROBLEM - Flushing diaphragm valve is not closing during start-up.

Possible Causes:

1. System pressure is too low to close the valve.
2. An object has lodged in the valve preventing full closure.
3. Solenoid not installed properly.

Solutions:

1. Partially close a valve downstream of the filter to maintain 2 bar (30 psi) on filter gauges. This pressure will ensure valve closure and supply back pressure necessary to clean the screen.
2. Disassemble the flush valve and remove the object. Check to ensure that the valve actuates properly.
3. Check solenoid installation diagram provided with installation instructions.

### 8.2 PROBLEM - Differential pressure never decreases, only builds.

Possible Causes:

1. Flushing valve is installed backwards.
2. Filter is installed backwards.

Solutions:

1. Install according to directional arrow.
2. Ensure filter inlet connected to (unfiltered) incoming water supply.

### 8.3 PROBLEM - Flush valve chatters

Possible Cause:

1. Air in the valve bonnet.

Solutions:

1. Manually flush filter several times to flush air from bonnet, the controller tank, and the filter tank.
2. Add a 13 mm (½ in) or 25 mm (1 in) air vent/vacuum relief to the flush line.

## 8.4 PROBLEM - Frequent or continuous flushing

Possible Causes:

1. Downstream pressure is not available to provide adequate cleaning power.
2. Filter may have been shut down “dirty” with a contaminant that is difficult to remove after it sets on the screen.
3. The differential pressure setting on the DP gauge at the base of the controller is set too low or does not stay set.
4. Dirt load is too high and/or flow rate exceeds maximum specified flow.
5. Screen may be partially plugged.
6. Rotor may be jammed which results in only cleaning the screen area that is directly in front of the nozzles.
7. A relatively large object or obstruction at the filter inlet is causing appreciable pressure drop or a significant amount of large hard debris has collected on the outside of the coarse screen that does not readily break down from the flow of water across the coarse screen.
8. Dirt particles are not being removed from the fine filter screen due to:
  - particle embedment.
  - particle bonding.
  - the dirt collector does not function during backflush.
  - the dirt collector does not rotate during backflush

Solutions:

1. Partially close downstream valve. Filter gauges should read 2 bar (30 psi).
2. A power flush needs to be performed as follows: a downstream valve should be closed or partially closed, providing that the static pressure against the valve does not exceed 5.5 bar (80 psi). After the valve is adjusted, cycle the filter through several long flushing. This process uses the entire available system pressure in the filter cleaning process.

3. Adjust DP gauge to a higher differential pressure setting (0.5 bar or 7 psi is recommended). If the adjustment does not stay at the desired setting, but falls down to 0 psi, replace the DP gauge.
4. Reduce flow rate through the filter. If reducing the flow rate, reduces backflush frequency, it may be advisable to install a fine screen with larger openings and/or install additional filters to provide additional screen area.
5. Perform power flush as described previously.
6. Open tank and check for free movement of rotor mechanism. If rotor does not rotate freely find cause of jamming and eliminate. If no cause can be found, inspect pawl for wear or damage.
7. Depressurize and drain the filter. Remove the filter cover and pull the coarse screen out of the coarse screen chamber. Wash and rinse all debris from the coarse screen. Check the filter inlet for objects and remove any if found. If no objects or debris are found, proceed to solution 8.
8. Depressurize and drain the filter. Disconnect the tubing to the piston. Remove the filter cover and pull the coarse screen. Remove the internal assembly and check rotation and transverse movement of the dirt collector. Remove the filter screen and check for blockage. Consider the following solutions based on your observations:
  - Particle Embedment—the size, shape and type of article may be imbedding into the pores of the filter screen. Analyze the dirt particles for size, shape and type and then determine whether or not a different screen design or screen mesh size would be more appropriate for your application. Contact VAF Filtration Systems for consultation.
  - Particle Bonding—the particles may be bonding to the surface of the filter screen. Analyze the dirt particles and then determine whether or not a different screen design or screen mesh size would be more appropriate for your application. Contact VAF for consultation.
  - Resistance to Dirt Collector Movement—Upon checking for movement of the dirt collector, if resistance is detected, check for contact between the dirt collector nozzles and filter screen. Remove any obstructions.
  - Resistance to Dirt Collector Rotation—Upon checking for rotation of the dirt collector, if resistance was detected, check for contact between the dirt collector nozzles and filter screen. Nozzles should clear the fine screen by approximately 3 mm (1/8"). If the nozzles are rubbing the screen, contact VAF for possible solutions.

## 8.5 PROBLEM - Water exiting the filter outlet is not sufficiently clean.

Possible Causes:

1. The pore size of the screen mesh is larger than particles in the water.
2. The differential pressure for flushing across the filter is set too high.
3. The filter screen has developed a sizable hole through which the dirty water can pass.
4. The O-ring seal between filter body and one of the bulkheads is damaged or not properly seated on the sealing surface.

Solutions:

1. Try a new filter screen with a mesh size that captures enough particles, bringing the outlet water to a sufficiently low level of dirt concentration.
2. The differential pressure setting at the DP gauge is too high, resulting in excessive pressure on the particles which forces them through the screen; adjust the DP gauge to a maximum 0.5 bar (7 psi) pressure differential.
3. Replace the damaged filter screen with a new screen; determine how the screen was damaged and correct the problem.
4. Replace O-rings at the top and bottom of the internal assembly and properly install the screens within the screen chambers.

## 8.6 TROUBLESHOOTING HINTS:

External Observations:

1. Observe the backwash indicator during backflush, checking for full travel.
2. Check the DP gauge during backflush to verify the needle returns to near zero at the end of the backflush cycle.
3. Check the discharge piping to verify that dirty water is discharged only during the backflush cycle.

Possible Reasons for Observations:

1. The indicator may not pop due to obstruction inside the filter or the dirt collector not rotating. Magnetic particles such as iron in the water can accumulate on magnet over time. Take the filter offline and check the filter internals including the magnet at the end of the shaft.

2. If the backwash cycle terminates before full travel of the backwash indicator pops, increase the setting on the BACKWASH TIME to allow full travel of the dirt collector.
3. If the needle on the face of the DP gauge does not return to near zero after the rinse cycle, then the filter screen is probably not being thoroughly cleaned. Check the prefilter screen and cleaning pattern left on the fine screen immediately after a backwash cycle to determine the cause for malfunction.
4. If the flush valve does not open, then either the flush valve is not being energized or an obstruction prevents the flush valve from opening. Check the electrical and hydraulic signaling that actuates the flush valve. Also, check for obstructions in the flush valve and discharge piping.

## 8.7 TROUBLESHOOTING DIAGNOSTICS:

1. Check for actuation of the solenoid valve by listening for two distinct clicking noises at the solenoid, once upon energizing and a second time when de-energizing.
2. Determine the pressure in all three internal compartments during normal filtration mode and during backflush mode by using the pressure gauge mounted to the 3-way valve; compare the pressure measurements to the pressure requirements for your filter. Also compute the differential pressure from measurements at the filter inlet and outlet and compare to the differential pressure read directly from the DP gauge.
3. Temporarily disconnect the hydraulic tubing at various fittings (one fitting at a time) on the filter body during normal filtration mode and backflush mode to determine whether or not pressurized water is available when it is supposed to be available.

---

**NOTE:** If corrosion is a concern utilizing a sacrificial anode is recommended. Contact our Aftermarket team to discuss options.

---

## 9.0 EXPLODED VIEW

COMPLETE INTERNAL	1001-0602
ELEMENT, V2000 XXX MICRON	VARIES
KIT, BASIC PARTS-V-3 & V-2000VERT	1002-2645
MONITOR PRESSURE SYSTEM 1000-3500	1001-6881

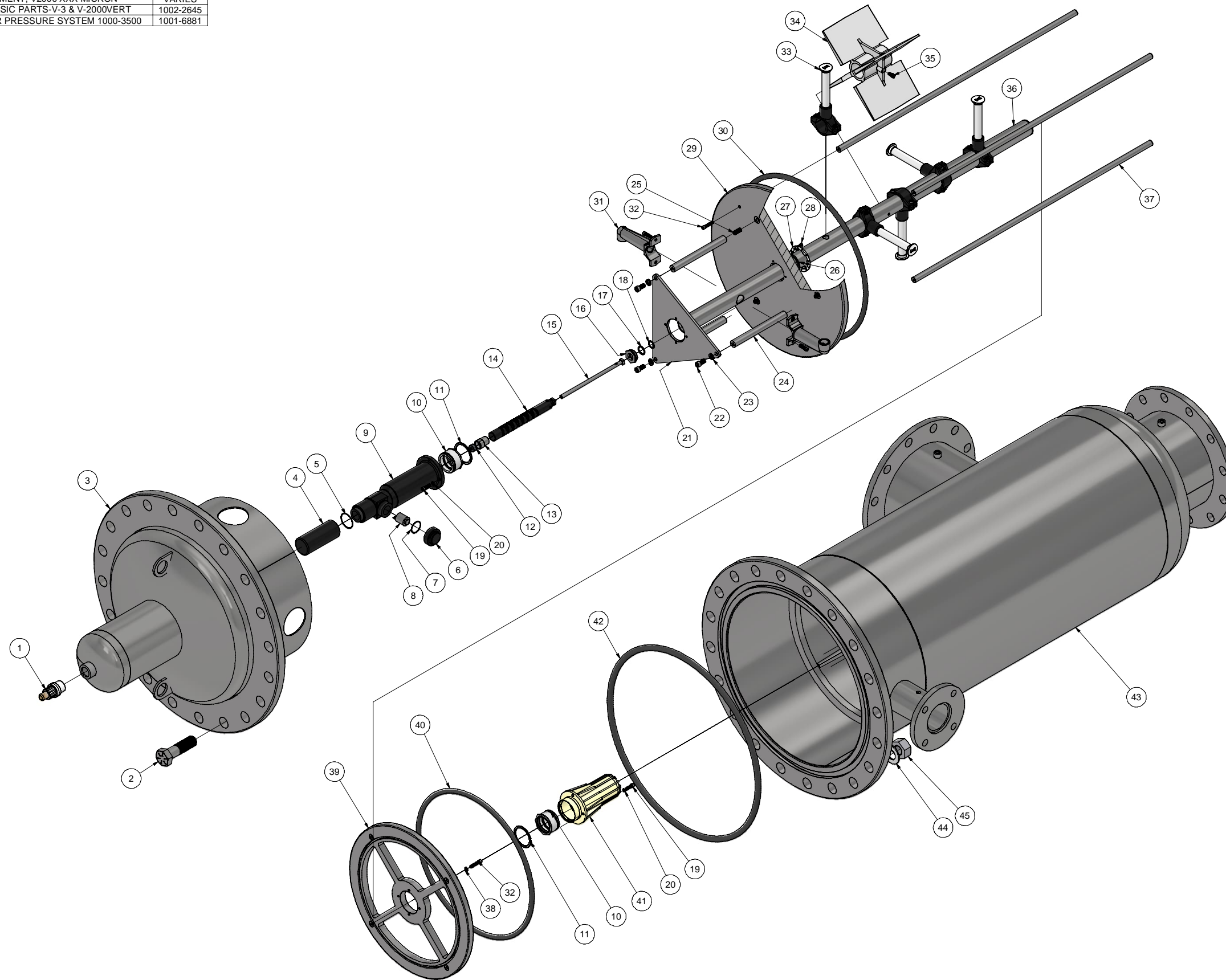

ITEM	QTY	PART NUMBER	DESCRIPTION
45	20	1002-5229	NUT, HEX 1-1/8IN ZINC PLATED 2000;
44	20	1002-5228	WASHER, FLAT 1-1/8 X 2.25 IN ZINC;
43	1	1002-5253	FILTER, V-3VERT-8 TANK ONLY
		1002-5228	FILTER, V-3VERT-10 TANK ONLY
		1002-5229	FILTER, V-3VERT-12 TANK ONLY
		1002-5252	FILTER, V-3VERT-14 TANK ONLY
42	1	1001-0510	O-RING, TANK 2000-V
41	1	1001-1247	CYLINDER, MACHINED 1000-2000 2000-V
40	1	1001-0499	O-RING, INLET BULKHEAD 2000-V
39	1	1001-1057	BULKHEAD, INLET 316SS 2000-V MACH
38	4	1001-0744	WASHER, LOCK 1/4 MED SPLIT;
37	4	1001-1077	BAR, TIE 316SS 2000/2000-V
36	1	1001-0833	TUBE, DIRT COLLECTOR 2000-V FINISHED
35	1	1001-0863	SCREW, SHC 1/4-20 X 1/2IN 316SS
34	1	1001-0796	SPEED REDUCER, 1000-2000 2000-V
33	6	1001-8768	KIT, VAC NOZZLE REPLACE 2000-2000-V
32	8	1001-1068	SCREW, SHC 1/4-20 X 1-1/4IN 316SS;
31	1	1001-0725	KIT, WATER MOTOR ASSY 1500-2000 2000-V;
30	1	1001-0498	O-RING, OUTLET BULKHEAD 2000-V
29	1	1001-1035	BULKHEAD, OUTLET 316SS 2000-V MACH;
28	3	1001-0053	SCREW, FHSC 8-32 X .5" 316 SS
27	1	1001-0051	RETAINER, SEAL WASHER 250-2000 2000-V;
26	1	1001-0049	SEAL, WASHER 1000-2000 2000-V
25	3	1001-0984	SCREW, SET CUPPOINT 3/8-16 X 1.25";
24	3	1001-0979	SPACER, STAND OFF 316SS 1000-2000
23	3	1001-0746	WASHER, SPLIT LOCK LOCK 3/8IN 316SS
22	3	1001-0987	SCREW, SHC 3/8-16 X 1";
21	1	1001-0998	PLATE, MOUNT 316SS 2000-V MACHINED
20	8	1001-0521	WASHER, SPRING LOCK 1/4IN;
19	8	1001-0743	SCREW, SHC 1/4-20 X 7/8 316SS;
18	1	1001-0948	RING, RETAINING SPIRAL .698 ID 316 SS
17	1	1001-0949	WASHER, THRUST 2000-V
16	1	1001-0943	NUT, REVERSER/SCANNER 2000-V 316SS
15	1	1001-0945	HOLDER, REVERSER 2000-V
14	1	1001-0947	REVERSER, SLEEVE 2000-V
13	1	1001-0946	NUT, REVERSER 2000-V
12	1	1001-0777	MAGNET, FOR ROTOR ASSY 250-3500;
11	2	1001-0914	RING, RETAINING 2.473 OD 316 SS
10	2	1001-0933	BUSHING, ASSY 1000-2000 2000-V;
9	1	1001-0755	HOUSING, REVERSER 2000-V
8	1	1001-0770	PAWL, REVERSER 2000-V - 3500 JULY 2009+;
7	1	1001-0517	O-RING, EPDM-70 -026;
6	1	1001-0959	CAP, PAWL RETAINER 2000-V
5	1	1001-0965	O-RING, EPDM-70 -030
4	1	1001-0966	COVER, REVERSER 2000-V
3	1	1001-0414	LID, 316SS 2000-V
2	20	1001-0474	BOLT, LID 1-1/8-7 X 4 ZINC PLATED;

STD:22x34\_D v4.42 BAR = 1" AT PLOT SCALE

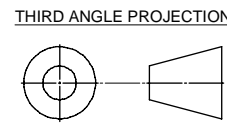

DRAWN PER ASME Y14.5M UNLESS OTHERWISE SPECIFIED. ALL WELD SYMBOL DIMENSIONS ARE MINIMUM. ALL DIMENSIONS ARE INCHES, DIMENSIONS IN [mm] ARE MILLIMETERS. WEIGHTS ARE POUNDS, AND TOLERANCES TO BE AS FOLLOWS:

FABRICATION	MACHINE
XX ± .06	.XX ± .03
[X ± 2]	.XXX ± .005
< ± 2	[X ± 1]
	[X ± .1]
	< ± 1

REV	DESCRIPTION	DATE	DWN	CKD	APPD	ECN
3	ITEM #33 UPDATED	2024-03-12	V.DHARMA	Y.BALU	J.BREWER	0217
2	REDRAWN	2021-12-03	RVR	JPB	JPB	----

FOR SCREEN OPTIONS, CONTACT VAF  
 COMPANY CONFIDENTIAL INFORMATION  
 THIS DOCUMENT AND ALL INFORMATION CONTAINED HEREIN, INCLUDING THE DESIGN CONCEPTS AND THERE ARISING THEREFROM ARE THE PROPERTY OF VAF SCREEN FILTERS AND/OR ITS AFFILIATES AND ARE SUBMITTED IN CONFIDENCE. THEY MAY BE USED ONLY FOR THE EXPRESS PURPOSE FOR WHICH THEY ARE PROVIDED AND MUST NOT BE DISCLOSED, REPRODUCED OR COPIED IN ANY FORM, INCLUDING IN ELECTRONIC FORMAT, LOANED OR USED IN ANY OTHER MANNER WITHOUT THE EXPRESS WRITTEN CONSENT OF VAF SCREEN FILTERS. ALL PATENT RIGHTS ARE RESERVED. THIS DOCUMENT AND DERIVATIVE WORKS THEREOF ARE PROTECTED UNDER APPLICABLE COPYRIGHT LAWS. UPON DEMAND OF VAF SCREEN FILTERS, THIS DOCUMENT, ALONG WITH ALL COPIES AND EXTRACTS, AND ALL RELATED NOTES AND ANALYSES MUST BE RETURNED TO VAF SCREEN FILTERS OR DESTROYED, AS INSTRUCTED BY VAF SCREEN FILTERS. ACCEPTANCE OF THE DELIVERY OF THIS DOCUMENT CONSTITUTES AGREEMENT TO THESE TERMS.

DWN BY:	DATE	TITLE
IAF	2020-01-28	V-3VERT EXPLODED VIEW
CKD BY:	DATE	CLIENT
JPB	2020-01-28	
APPD BY:	DATE	
JPB	2020-01-28	
MGD BY:	SCALE	
JPB	NTS	

<b>VAF</b> Screen Filters	VAF Screen Filters 5640 Logistics Dr #100, Alpharetta, GA 30004 Phone: 470-222-2890 Email: solutions@fisbrands.com
------------------------------	---

PROJ/PROD NUMBER	CODE	FILE/DRAWING NUMBER	SHEET	REV
		V-3VERT EV	1 OF 1	3